

Vickrey Auctions with Sequential and Costly Participation*

Guoqiang Tian

Department of Economics

Texas A&M University

College Station, Texas, 77843

U.S.A

Mingjun Xiao

School of Economics

Shanghai University of Finance and Economics

Shanghai, 200433

China

January 14, 2009

Abstract

This paper investigates the cutoff strategies and the effects of sequential and costly participation in Vickrey auctions with independent private value settings. It demonstrates a Stackelberg version of participation decision in auctions, while simultaneous participation can be regarded as a Cournot version in auctions. Buyers adopt cut-off participation strategies. In two-buyer case, the cutoff strategy equilibrium is unique. The follower's critical values are always monotonic in participation cost in both symmetric and asymmetric settings. This is also true for the leader with mild conditions on c.d.f.s. We also characterize equilibria in three-buyer and more general n -buyer environments. We then study buyer's preference to be a leader or a follower. Comparison with simultaneous model shows that the *driven-out effect* is much stronger in our sequential participation model, which implies the simultaneous specification might not be desirable.

Keywords: Sequential Participation, Participation Cost, Second Price Auction.

JEL Classification: C72; D44; D80.

*We thank Ning Sun, Hongjun Zhong and Xiaoyong Cao for helpful comments and suggestions. Financial support from the National Natural Science Foundation of China (NSFC-70773073) and the Program to Enhance Scholarly and Creative Activities at Texas A&M University as well as from Cheung Kong Scholars Program at the Ministry of Education of China is gratefully acknowledged. E-mail address: gtian@tamu.edu (Guoqiang Tian), mjxiao@gmail.com (Mingjun Xiao).

1 Introduction

1.1 Motivation

Auction is a trade mechanism widely used in economic activities, which can enhance the competition among buyers when a seller has incomplete information about buyers' willingness to pay for an underlying object, project or service(s). In auctions, bidders may necessarily bear some cost before they can submit their bids. Such kind of cost in auctions, without accurate informative classification or definition, could be referred to as participation cost in general. For example, a buyer may acquire relevant information to estimate its value, which leads to cost in both money and time. In procurement auctions a bidder should carefully prepare a detailed plan that specifies each provision listed in the project announcement, possibly including the certifications that make the bidder qualified as a legal candidate to submit its document, which is costly for bidders. In many auctions, buyers need to register for being a legal bidder by incurring a cost. This registration cost, or entry fee may be paid directly to the seller for arranging the auction itself.

In economic circumstances, the cost incurred always appears to be a primary consideration for agents. This is also the case in auctions where participation cost plays a significant role in functioning the allocation efficiency and revenue of auctions as well as other performance indicators. It is well-known that bidders have weakly dominant strategy to bid their true values in standard second price sealed bid auction (abbreviated as SPA) stated in Vickrey (1961), but this would be true only if bidders find it optimal to participate in the auction when there exists participation cost. Participation cost can influence both allocation efficiency and all agents' payoffs, including the revenue of the seller and net payoff of bidders. Actually in order to stay at the stage of submitting bids, almost every bidder has to bear some cost. This means every bidder first needs to make a decision whether they should participate. Usually this participation decision is not made simultaneously, for example, the buyer who registers to be a bidder can observe those buyers who have already registered at registration office. This additional information may help the buyer to identify the types of their opponents, hence influences the buyer's participation decision.

Sequential entrance is best illustrated in the acquisition of Unocal Corporation by China National Offshore Oil Corporation (CNOOC) and Chevron Corporation in 2005. In March, CNOOC tried to acquire Unocal Corporation with a bid of \$18 billion. After careful preparation, Chevron submitted its bid to acquire Unocal in June. In the end, Chevron won the competition.¹

¹Failing to pass the vote in the United States House of Representatives, CNOOC's bid was referred to President George W. Bush for evaluations on national security. In this situation, CNOOC withdrew its bid on August 2. Soon after, Unocal merged with Chevron on August 10, 2005.

In daily life, sequential participation can be observed in many activities. The house sale serves as a typical example. Naturally one house on sale may attract several purchasers' attention. The salesman would accompany each client to look around the house at different time, to know about her/his demand requirement. When a salesman introduces the house to a potential purchaser, he usually tells the client there are other clients having shown interests in this house and advertises the advantageous characteristics of the house, such as natural environment, transportation convenience, schooling, etc. Since each buyer negotiates with the salesman separately and reports his/her desirable price directly to the property developer, such a sale procedure could be modeled as a sealed-bid price auction. Other examples include special certification examinations, entrance examinations for government functionary, or other career-relevant examinations. These testing services usually announce some of their registration information publicly, namely, the number of registered testees, so test takers can get sketchy information before registering for the exam. In some economic environments, potential buyers can also obtain information concerning the participants from official channels, i.e., government procurements, corporation-merger activities as well as some types of online auctions.

Our observation then is that if one buyer can observe the participation of those who enter into the auction before her, the information she has observed would discourage her from participating in the auction, where participation cost could be very small if the number of participants is large.² We call this *driven-out effect*. Such kind of information structure has not been investigated yet in auctions with endogenous entry.

1.2 The Objective of the Paper

In this paper, we establish an IPV (independent private value) single-object Vickrey auction model in which participation is costly and potential buyers participate sequentially. We assume that a buyer observes the entry decisions of those participants who take actions before her, and then makes her own participation decision. Our specification differs from those simultaneous participation models in both information structure and equilibrium strategies. First, in our model the buyer except for the first one can update her belief on opponents' valuations by observing those who participate before her. Due to the sequential entrance, buyers' information are asymmetric, namely, the i th buyer has a $(i - 1)$ -dimension signal concerning her opponents' entrance. But in simultaneous model, buyers have no information on their opponents' participation, and buyers are symmetric if ignoring their distributions of values. Secondly, each potential buyer has to specify her participation decision for every possible sequence of participation de-

²For simplicity, we only consider the environment in which the information concerning opponents' participation does not influence buyer's own evaluations, for example, buyers' values are independently distributed.

cision she observes in our model, while in simultaneous model the buyer's participation choice only depends on her valuation of the object.³ When focusing on cutoff strategies, each buyer needs to determine a set of cutoff points in our mode while she only has to set one cutoff point in simultaneous setting. This is due to the sequential structure of the game, i.e., each buyer's entrance choice partially reveals her valuation to opponents entering after her.

We then investigate the cutoff strategies and the effects of sequential and costly participation. In two-buyer case, the cutoff strategy equilibrium is unique. The follower's critical values are always monotonic in participation cost in both symmetric and asymmetric settings. This is also true for the leader with mild conditions on c.d.fs. We also characterize equilibria in three-buyer and more general n -buyer environments. We then study buyer's preference to be a leader or a follower.

We also find a low participation cost can discourage buyers from participating in the auctions if there are many potential buyers, and in our terminology the *driven-out effect* is very strong in sequential participation settings. A natural implication would be that the simultaneous participation model might not be appropriate to describe the competition in auctions when buyers have access to receiving information on others' entrance.

1.3 Related Literature

The existing literature on equilibrium characterization on auctions with participation cost mainly focuses on simultaneous participation. When there exists participation cost, the participation itself would be part of equilibrium strategies, hence it is called endogenous entry. In the initial work in this field, Samuelson (1985) derived the symmetric entry equilibria that maximize the social welfare and the sellers expected revenue in procurement with symmetric buyers. Green and Laffont (1984) established a model to incorporate the buyers' willingness to pay and reservation utility into the auctions, which is equivalent to setting participation cost for buyers.

Later many researchers examine the settings of auctions with private values and entry cost. Levin and Smith (1994) showed that the revenue equivalence can also be held in this environment with endogenous entry, and the seller should not set reservation price or charge entry fee, since discouraging entry is not optimal for the seller. Menezes and Monteiro (2000) established the revenue equivalence between first and second price sealed bid auctions, and showed that seller's expected revenue could decrease as the number of potential buyers increases. In contrast, Stegeman (1996) focused on the theme of allocative efficiency between different auction formats, and found that second-price auction has ex ante efficient equilibrium while first price auction has not

³Actually, the cutoff point also relies on the prior belief on opponents' value distributions, which is assumed to be fixed when making this comparison.

such an equilibrium even with symmetric buyers. Chakraborty and Kosmopoulou (2001) considered the revenue equivalence problem if there exist both preparation cost and entry fee, and the revenue equivalence does not hold in their model. Besides, Matthews (1987), McAfee and McMillan (1987) and Harstad et al. (1990) directly investigated models in which the number of bidders are random, according to a known distribution.

Tan and Yilankaya (2006) explored the equilibrium strategies for bidders in second price auction in IPV setting, where all bidders are ex ante symmetric, namely, participation cost is the same for all bidders. Lu (2006) gave a more detailed description of participation strategies and the patterns of equilibria along this strand of research. Cao and Tian (2008b) investigated the equilibrium strategies for bidders by relaxing the participation cost to be asymmetric, i.e. each bidder bears its own specific cost. They have confirmed that concavity of bidder's valuation distribution functions can promise the uniqueness of cut-off strategy equilibrium.⁴ The asymmetric environment was also explored by Kaplan and Sela (2003, 2006), Moreno and Wooders (2006), etc. Celik and Yilankaya (2008) studied a costly entry model with IPV setting aiming to find the optimal auction format, and they specified the conditions under which the seller obtains maximal profit in second price auction.

Different from all the simultaneous entry models—a Cournot version of participation in auctions, this paper investigates how sequential and costly participation—a Stackelberg version of participation in auctions affects the properties of the Vickrey auction, or the second price auction mechanism where potential buyers make participation decision sequentially and can observe the participation decision of the former buyers at the time of making this choice.

The remainder of this paper is organized as follows. Section 2 describes the basic setting of the model. Section 3 characterizes buyers' behavior in equilibrium. Section 4 discusses the buyers' incentives to be a leader or a follower. Section 5 compares the auction game with sequential participation and the auction game with simultaneous participation specifications. Section 6 concludes. All proofs are relegated to the Appendix.

2 The Setup

There is a single object to be sold by employing a standard second price sealed bid auction. n potential risk neutral buyers indexed by $i \in \{1, 2, \dots, n\}$ compete for the object. The values of the buyers are independently distributed on the support $[\underline{v}, \bar{v}]$, where $-\infty < \underline{v} < \bar{v} < +\infty$.⁵

⁴Cao and Tian (2008a) also considered the entrance strategies and bidding rules for bidders in first price sealed bid auctions still within the IPV settings.

⁵Here we do not need \underline{v} or \bar{v} to be positive. For example, this environment could include the government procurement of some public project, in which the negative value of the seller means the cost that the seller would like to incur to complete the project and the negative price for the winning buyer refers to the compensation for

Buyer i 's value follows the cumulative distribution function (c.d.f) $F_i(\cdot)$, where its density function $f_i(\cdot)$ is continuous and has full support on $[\underline{v}, \bar{v}]$. The owner of the object values it less than \underline{v} , and the reservation price is set at \underline{v} .

The buyer needs necessarily to incur a participation cost c , which is the same for all potential buyers, to be a legal bidder for participating in the auction and submitting its bid. The cost c takes value from the support $(0, \Delta v]$, where $\Delta v = \bar{v} - \underline{v}$. Buyers sequentially decide whether to participate in the auction. Without loss of generality, buyers make their participation decisions sequentially in the order of $\langle 1, 2, \dots, n \rangle$. When a buyer makes her participation choice, she can observe all participation decisions of those buyers in the entrance order before her. For example, buyer 1 will decide first whether she should enter into the auction without any further information coming through, then buyer 2 makes her participation choice after observing buyer 1's action, then it's the turn of buyer 3, and so on.

Define the feasible action set for buyers by $\{\mathcal{N}\} \cup [\underline{v}, \bar{v}]$. Here a report " \mathcal{N} " means the buyer does not participate in the auction. A buyer participates in the auction if and only if she reports some value no less than \underline{v} , which is denoted as b_i . Let the reported value $b_i \in [\underline{v}, \bar{v}]$ be the buyer i 's bidding strategy.⁶ Since buyers other than the first one can observe formers' participation decisions, which is a signal that conveys information on former opponents' types, the buyer's participation choice and her bidding rule both depend on her own value of the object and the signal she has observed. Let the support of buyer i 's signal be $\{N, P\}^{i-1}$, where a N represents that a buyer does not participate and a P says she does. Let $s_i \in \{N, P\}^{i-1}$ denote buyer i 's signal before her participation, where the j th element of s_i refers to buyer j 's participation choice. For simplicity, we let $s_1 \in \emptyset = \{N, P\}^0$ denote buyer 1's signal which tells nothing.

It is obvious that if a buyer prefers participating in the auction, he should report his true value since truth-telling remains the weakly dominant strategy for the buyer conditional on her participation under the rules of the second price auction. Thus, we can confine ourselves to the so-called cutoff-strategy Bayesian Nash equilibria in which the buyer participates in the auction if and only if her value exceeds some critical point.⁷ Note that the critical point of a buyer depends on her received signal. Let $x_{i,s_i}^{(n)}$ be the cutoff point of buyer i who receives a signal s_i . Here we use the superscript (n) to refer to potential n buyers, distinguished from normal power

building the project. In this sense, the only thing that matters is the boundedness of the support, for example, $-\infty < \underline{v} < \bar{v} < +\infty$.

⁶In principle, b_i could be any real number that exceeds the reservation price, but putting an upper bound for the report does not give any active restriction on buyers' behavior since in second price auction buyers have weakly dominant strategy to report truthfully conditional on participation.

⁷It is evident that in Vickrey auctions buyer bids her valuation conditional on participation, therefore, buyer's payoff is strictly increasing in her valuation. This in turn implies that buyer gets zero payoff for at most one type at which she will be indifferent between participating and not participating. This is also true in simultaneous participation models.

index, the subscript i to index buyer i , and s_i to buyer i 's signal. Sometimes for convenience, the comma between i and s_i in the subscript of the critical point $x_{i,s_i}^{(n)}$ is also omitted.⁸ Then the equilibria of our models share the same characteristics with the ones in Cao and Tian (2008b), i.e., a buyer i who has value v_i and receives a signal s_i would report

$$b_i(v_i, s_i) = \begin{cases} \mathcal{N} & \text{if } v_i < x_{i,s_i}^{(n)}; \\ v_i & \text{if } v_i \geq x_{i,s_i}^{(n)}. \end{cases} \quad (1)$$

3 Sequential Participation

3.1 Two Symmetric Buyers

In this subsection we analyze the simplest two-buyer case with the leader's and the follower's valuations following the same distribution $F(\cdot)$. We omit the superscript in buyers' cutoff points for convenience. One can expect that when participation cost is large, i.e., close to \bar{v} , the follower may never participate after observing the leader's participation. To characterize different types of equilibrium cutoff points, we define a critical value of the participation cost c_0 , which is implicitly given by the equation

$$\frac{1}{1 - F(c_0 + \underline{v})} \int_{c_0 + \underline{v}}^{\bar{v}} (F(v) - F(c_0 + \underline{v})) dv = c_0. \quad (2)$$

In addition, set K as any real number larger than \bar{v} . We then have the following proposition.

Proposition 1 *The auction game has a unique cutoff strategy equilibrium in which:*

- (1). *If the participation cost $c \in (0, c_0]$, then $x_{2N} = c + \underline{v}$, and x_1 and x_{2P} ($x_{2P} > x_1$) are implicitly given by the equation system*

$$(x_1 - \underline{v})F(x_{2P}) = c, \quad (3a)$$

$$\frac{1}{1 - F(x_1)} \int_{x_1}^{x_{2P}} (F(v) - F(x_1)) dv = c; \quad (3b)$$

where x_1 refers to the critical value of the leader, x_{2N} represents the critical value of the follower who observes the leader's non-participation, and x_{2P} represents the critical value of the follower who observes the leader's participation.

- (2). *If the participation cost $c \in (c_0, \Delta v]$, then $x_1 = x_{2N} = c + \underline{v}$, and $x_{2P} = K$.*

⁸For example, the notation $x_{3NP}^{(3)}$ refers to the critical point of buyer 3 who observes buyer 1 does not participate but buyer 2 participates.

Remark 1 When $c = c_0$, we have $x_1 = x_{2N} = c + \underline{v}$, $x_{2P} = \bar{v}$.

We can see that for a large cost $c \in (c_0, \Delta v]$, the follower would not participate on observing the leader's participation. So she is driven out of the auction game. The Figure 1 illustrates the equilibrium strategies in Proposition 1 for $c \in (0, c_0]$. The smallest black area represents the case in which neither buyer participates in the auction. The left middle-sized grey area means only the follower participates and the bottom middle-sized grey area says only the leader participates. The largest white area demonstrates both buyers' participation. The leader's critical point x_1 is the knife cutting the figure into two parts, and the follower's critical values x_{2N} and x_{2P} continue to give another two cuts, one in each part.

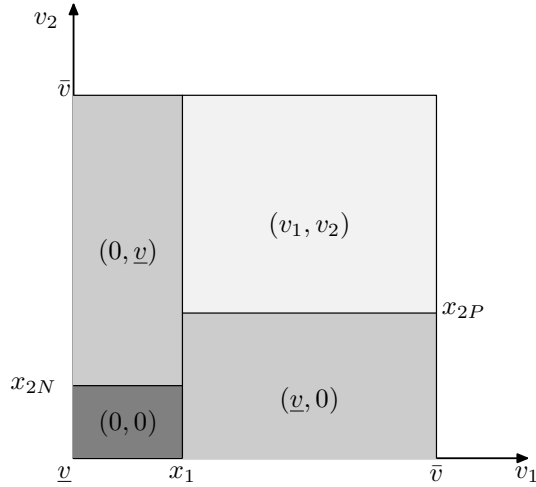

Figure 1: Equilibrium Strategies with 2 Buyers

One may naturally expect that if the participation cost increases, the buyer would be less likely to participate in the auction. In other words, the critical values are increasing functions in participation cost. The results are summarized in the following proposition.

Proposition 2 *The follower's critical values x_{2N} and x_{2P} are strictly increasing as participation cost goes up. The leader's critical point x_1 is also increasing in participation cost if the c.d.f $F(\cdot)$ is concave.*⁹

It may be remarked that, while it is relatively easy to show that the follower's critical values are always monotonic within the setting, it is hard to show the monotonicity of the leader's critical value. As such, we need to impose an additional assumption—the concavity of $F(\cdot)$. To

⁹The concavity of c.d.f is a requirement that can promise the uniqueness of symmetric cutoff strategy equilibrium and exclude asymmetric cutoff strategy equilibrium in symmetric setting, i.e., see Tan and Yilankaya (2006) and Celik and Yilankaya (2008), or uniqueness of equilibrium in asymmetric setting, i.e., see Cao and Tian (2008a, 2008b), and references therein. However, the main result in this paper does not rely on the uniqueness of the equilibrium.

explain this, we need to identify two effects caused by an increment in participation cost. The first one is called *direct effect*. That is, the net payoff of a buyer who participates would be decreasing when keeping her opponent's cutoff point(s) unchanged, which causes her own cutoff point(s) to go up. The other one is called *indirect effect*. That is, an increase in opponent's critical value (caused by an increase in c) means an increment in the probability of the opponent's non-participation, in other words, an increment in the probability that the buyer wins against her opponent at reservation price, which leads a buyer's critical value to decrease. In general, the indirect effect is very small. Also the indirect effect can dominate the direct one at most for one buyer, since at least one of the buyer's critical value(s) should increase when cost goes up.

Since the leader has first-mover advantage,¹⁰ she can keep her critical value x_1 unchanged temporarily and wait for the follower's cutoff point x_{2P} to rise up when participation cost increases. In equilibrium, the follower should expect the leader's action correctly and set a higher critical value x_{2P} accordingly. Therefore, the direct effect always dominates the indirect one for the follower, and it is possible theoretically that the dominance relationship is reversed for the leader without additional assumptions. The concavity of $F(\cdot)$ can promise that the direct effect plays the main role for the leader. The intuition is as follows. A concave c.d.f means a weakly decreasing density of buyers' values, so the indirect effect is most significant at critical values close to \underline{v} when cost c is sufficiently small. However, x_1 is increasing in c at neighborhood of zero, thus the concavity can promise the monotonicity of the leader's critical value.

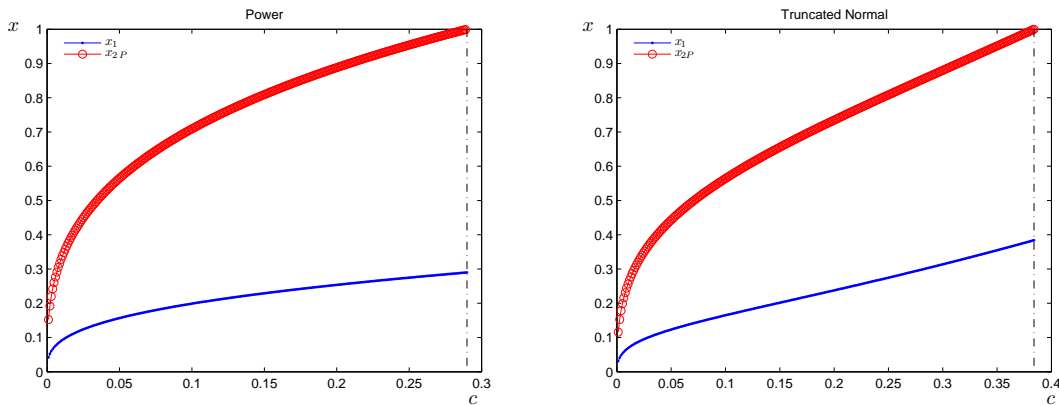

Figure 2: Monotonicity of Cutoff Points. Numerical specifications for simulation: $\underline{v} = 0, \bar{v} = 1$; for power distribution $F(x) = x^q$ and $q = 2$, for truncated normal $F(x) = \psi(x|\mu, \sigma)/(\Psi(1|\mu, \sigma) - \Psi(0|\mu, \sigma))$ and $\mu = 0.5, \sigma = 0.25$, where $\psi(\cdot|\mu, \sigma)$ and $\Psi(\cdot|\mu, \sigma)$ are normal density and cumulative function respectively with mean μ and standard deviation σ .

¹⁰The meaning of the term ‘‘first-mover advantage’’ is widely used, and is formally illustrated by Gal-Or (1985) with continuous choice variable. The term here does not necessarily have the same notion as Gal-Or’s model, since in our model buyers only choose participation or not and their bidding rules are given conditional on participation.

Numerical simulation shows that the monotonicity is generally true, since we have not found a counterexample amongst the usual distributions, including those that are not concave. Figure 2 shows the simulated cutoff points as participation cost varies from zero to c_0 with power distribution and truncated normal distribution, which are not concave at parameter values we have specified. The monotonicity is pretty robust to the parameters of those distributions, namely q for power distribution and μ and σ for truncated normal.

3.2 Two Asymmetric Buyers

When the potential two buyers are asymmetric, i.e., with heterogeneous c.d.f $F_i(\cdot)$, the sequential participation game has a very similar type of equilibrium except for redefining the threshold of the participation cost and adding an individual index to conditions in equation system (2). This can be verified by looking through the argument in the proof of Proposition 1. Again we should specify a critical value of the participation cost, \hat{c}_0 , which is implicitly given by

$$\frac{1}{1 - F_1(\hat{c}_0 + \underline{v})} \int_{\hat{c}_0 + \underline{v}}^{\bar{v}} (F_1(v) - F_1(\hat{c}_0 + \underline{v})) dv = \hat{c}_0, \quad (4)$$

only by replacing $F(\cdot)$ in the definition of c_0 with $F_1(\cdot)$.

Parallel to the symmetric setting, immediately we have the following proposition characterizing the equilibrium with asymmetric buyers.

Proposition 3 *The auction game has a unique cutoff strategy equilibrium in which:*

- (1). *Suppose participation cost $c \in (0, \hat{c}_0]$. Then $x_{2N} = c + \underline{v}$, and x_1 and x_{2P} ($x_{2P} > x_1$) are implicitly given by the equation system*

$$(x_1 - \underline{v})F_2(x_{2P}) = c; \quad (5a)$$

$$\frac{1}{1 - F_1(x_1)} \int_{x_1}^{x_{2P}} (F_1(v) - F_1(x_1)) dv = c. \quad (5b)$$

- (2). *Suppose participation cost $c \in (\hat{c}_0, \Delta v]$. Then $x_1 = x_{2N} = c + \underline{v}$, and $x_{2P} = K$.*

Remark 2 When $x_{2P} = \bar{v}$, equation (5a) implies $x_1 = c + \bar{v}$ and (5b) reduces to (4), which is the definition of \hat{c}_0 . Therefore, it is the condition $x_{2P} = \bar{v}$ that determines \hat{c}_0 .

We have known that it is generally true that monotonicity of cutoff points holds for all usual distributions in the case of two symmetric buyers. It might be interesting to check what happens in asymmetric settings. This leads to the following result:

Proposition 4 *The follower's critical values x_{2N} and x_{2P} are strictly increasing as participation cost goes up. The leader's critical point x_1 is also increasing in participation cost if buyer 1's c.d.f $F_1(\cdot)$ is concave and it dominates $F_2(\cdot)$ in terms of the reverse hazard rate,¹¹ i.e., for all $v \in (\underline{v}, \bar{v})$,*

$$\frac{f_1(v)}{F_1(v)} > \frac{f_2(v)}{F_2(v)}.$$

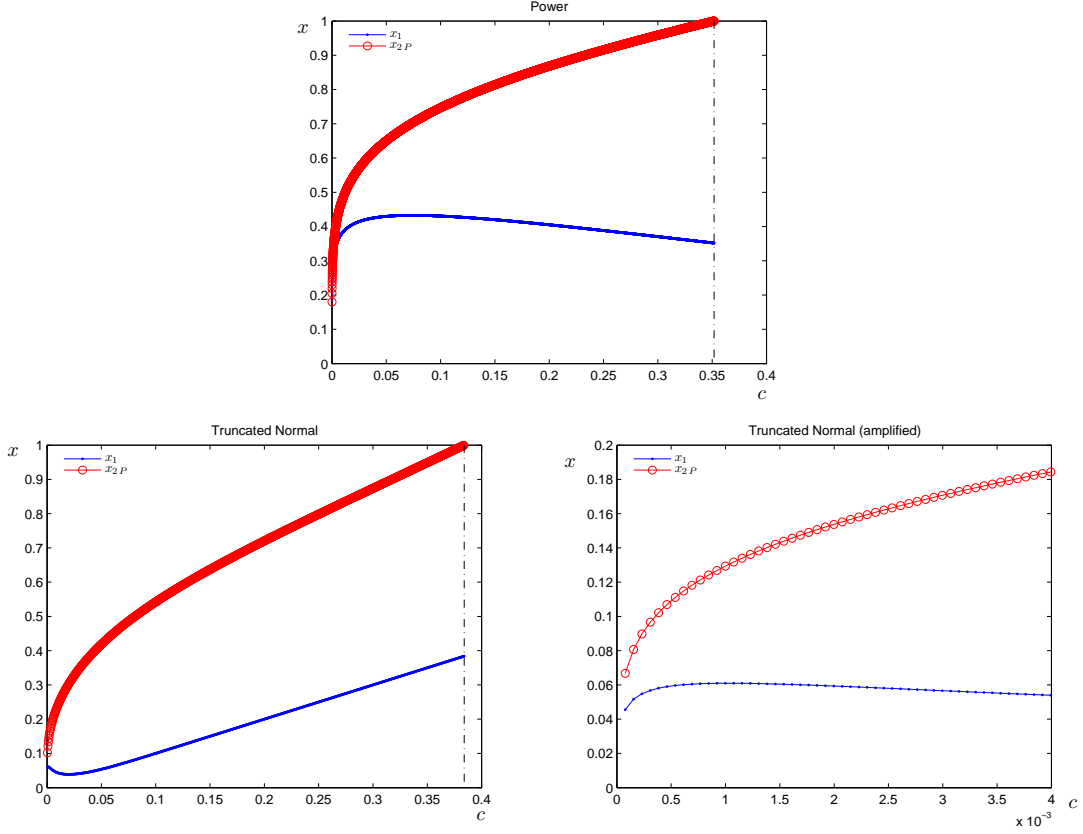

Figure 3: Non-Monotonicity of Cutoff Values under Asymmetry. Numerical specifications for simulation: $\underline{v} = 0, \bar{v} = 1$; for power distribution $F_1(x) = x^{q_1}, F_2(x) = x^{q_2}$ and $q_1 = 0.5, q_2 = 5$, for truncated normal $F_i(x) = \psi(x|\mu_i, \sigma_i) / (\Psi(1|\mu_i, \sigma_i) - \Psi(0|\mu_i, \sigma_i))$ for $i = 1, 2$, and $\mu_1 = 0.5, \sigma_1 = 0.25, \mu_2 = 0.3, \sigma_2 = 0.08$, where $\psi(\cdot|\mu_i, \sigma_i)$ and $\Psi(\cdot|\mu, \sigma)$ are normal density and cumulative function with mean μ_i and standard deviation σ_i , respectively.

The same as symmetric case, the monotonicity for the leader is ambiguous without additional assumptions. However, the concavity of $F_1(\cdot)$ and dominance in terms of reverse hazard rate again are sufficient conditions.

But different from the symmetric case, we do find non-monotonic property of cutoff value

¹¹The reverse hazard rate is usually used to compare the strongness of bidder in auction theory, i.e. the weaker bidder will bid more aggressively than a stronger bidder in first price sealed bid auctions if the weaker bidder is dominated in terms of reverse hazard rate, see Vijay Krina "Auction Theory" (2002), pp.47-49 for details.

x_1 when the conditions in Proposition 4 are not satisfied and the asymmetry between buyers is sufficiently strong. See Figure 3, which shows critical values x_1 and x_{2P} as functions of the participation cost for $c \in (0, \hat{c}_0)$. For power distribution, it is evident that x_1 is decreasing as c passes some threshold. In the *Truncated Normal* figure, we can also see x_1 is downward-sloping for a region of c . The sub-figure named *Truncated Normal(amplified)* gives a close look of variations of $x_1(c)$ when c is close to zero, which amplifies the first one percent part of the graph *Truncated Normal*.

This decreasing property of x_1 at a certain range of permissible participation cost support $(0, c_0]$ is very interesting. It says for some cost c' in this particular region, the leader with some critical value $x_1(c')$ would become better-off as cost increases a little bit. This is because, the leader with value $x_1(c')$ gets exactly zero expected payoff, but she can receive a positive surplus when participation cost increases a little to $c'' = c' + \epsilon$ by monotonicity of payoff in its own value and the decreasing property of x_1 , i.e. $x_1(c'') < x_1(c')$. Therefore, it is possible that for the two effects analyzed in asymmetric settings, the indirect effect dominates the direct one for the leader when asymmetry is strong enough.

3.3 More Buyers

Actually, the above analysis can be extended to general n -buyer case in a partially recursive way. It is convenient to investigate a three-buyer case with symmetric values for hint on general environment with more buyers. To begin with, we specify a threshold of participation cost c_1 and two critical cutoff values $x_1^{*(3)}$ and $x_{2P}^{*(3)}$, which are implicitly given by the following equation system:

$$(x_1^{*(3)} - v)[F(x_{2P}^{*(3)})]^2 = c_1, \quad (6a)$$

$$\frac{1}{1 - F(x_1^{*(3)})} \int_{x_1^{*(3)}}^{x_{2P}^{*(3)}} (F(v) - F(x_1^{*(3)})) dv = c_1, \quad (6b)$$

$$\frac{1}{[1 - F(x_1^{*(3)})][1 - F(x_{2P}^{*(3)})]} \int_{x_{2P}^{*(3)}}^{\bar{v}} [F(v) - F(x_{2P}^{*(3)})][F(v) - F(x_1^{*(3)})] dv = c_1. \quad (6c)$$

Without further assumption on $F(\cdot)$, the so-defined c_1 may not be unique. However, the concavity of $F(\cdot)$ can promise the uniqueness, which is summarized in the following lemma.

Lemma 1 *If $F(\cdot)$ is concave, then c_1 is uniquely determined by equation system (6a)–(6c), and $c_1 < c_0$.*

For sequential participation in auction with three potential buyers, the equilibrium is stated in the proposition below.

Proposition 5 *Suppose $F(\cdot)$ is concave. The three-buyer auction game has cutoff-strategy equilibrium in which:*

(1). For $c \in (0, \Delta v]$, the critical points $x_{2N}^{(3)} = x_1, x_{3NN}^{(3)} = x_{2N}, x_{3NP}^{(3)} = x_{2P}$, where x_1, x_{2N} and x_{2P} are critical values defined in Proposition 1 part (1).

(2). The other 4 critical points $x_1^{(3)}, x_{2P}^{(3)}, x_{3PN}^{(3)}$ and $x_{3PP}^{(3)}$ are specified in three different regions of participation cost.

(2.a). If the participation cost $c \in (0, c_1]$, then these four critical points are implicitly given by the equation system

$$(x_1^{(3)} - \underline{v})F(x_{2P}^{(3)})F(x_{3PN}^{(3)}) = c, \quad (7a)$$

$$F(x_{3PP}^{(3)}) \left[\frac{1}{1 - F(x_1^{(3)})} \int_{x_1^{(3)}}^{x_{2P}^{(3)}} (F(v) - F(x_1^{(3)})) dv \right] = c, \quad (7b)$$

$$\frac{1}{1 - F(x_1^{(3)})} \int_{x_1^{(3)}}^{x_{3PN}^{(3)}} (F(v) - F(x_1^{(3)})) dv = c, \quad (7c)$$

$$\frac{1}{[1 - F(x_1^{(3)})][1 - F(x_{2P}^{(3)})]} \int_{x_{2P}^{(3)}}^{x_{3PP}^{(3)}} [F(v) - F(x_{2P}^{(3)})][F(v) - F(x_1^{(3)})] dv = c, \quad (7d)$$

with constraints $x_{3PP}^{(3)} > x_{2P}^{(3)} > x_{3PN}^{(3)} > x_1^{(3)}$.

(2.b). If the participation cost $c \in (c_1, c_0]$, then $x_{3PN}^{(3)} = x_{2P}^{(3)}, x_{3PP}^{(3)} = K$, and $x_1^{(3)}$ and $x_{2P}^{(3)}$ ($x_{2P}^{(3)} > x_1^{(3)}$) are implicitly and uniquely given by

$$(x_1^{(3)} - \underline{v})[F(x_{2P}^{(3)})]^2 = c; \quad (8a)$$

$$\frac{1}{1 - F(x_1^{(3)})} \int_{x_1^{(3)}}^{x_{2P}^{(3)}} (F(v) - F(x_1^{(3)})) dv = c. \quad (8b)$$

(2.c). If the participation cost $c \in (c_0, \Delta v]$, then $x_1^{(3)} = c + \underline{v}$ and $x_{3PN}^{(3)} = x_{2P}^{(3)} = x_{3PP}^{(3)} = K$.

Remark 3 When $c = c_1$, the critical points given by the equation system (7a)–(7d) reduce to $x_1^{(3)} = x_1^{*(3)}, x_{2P}^{(3)} = x_{3PN}^{(3)} = x_{2P}^{*(3)}$, and $x_{3PP}^{(3)} = \bar{v}$.

Remark 4 Without the concavity of $F(\cdot)$, the equilibrium cutoff strategies characterized by Proposition 5 remain true. However, there might be very complicated switch in cutoff points

between different patterns in part (2.a) and part (2.b), since the so-defined cost c_1 might not be unique. Under concavity of $F(\cdot)$, the only open question is the existence of multiple solutions to equation system (7a)–(7d) for $c \in (0, c_1)$.

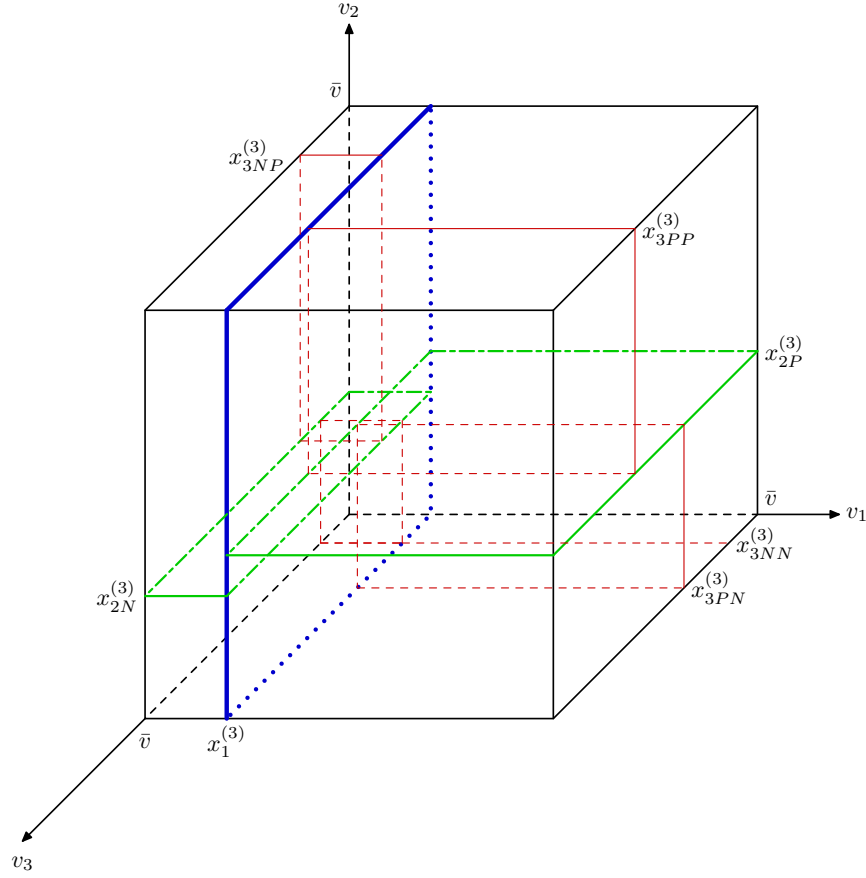

Figure 4: Equilibrium Strategies with 3 Buyers

If Buyer 1 does not participate in the auction, the participation decisions of Buyer 2 and Buyer 3 reduce to the two-buyer case, which yields part (1) of Proposition 5. If Buyer 1 participates in the auction, this is the case corresponding to the other 4 critical points for three bidders: $x_1^{(3)}$, $x_{2P}^{(3)}$, $x_{3PN}^{(3)}$ and $x_{3PP}^{(3)}$. A complete description of these four critical values depends on the scale of the participation cost. When c is small, i.e., $c \in (0, c_1]$, no buyer would ever participate regardless of her values, which is characterized by part (2.a) of the proposition. When cost c becomes moderate, i.e., $c \in (c_1, c_0]$, the third buyer who observes both buyer 1 and buyer 2's participation would never enter into the auction. This is what part (2.b) of the proposition says. If the participation cost is large, i.e., $c \in (c_0, \Delta v]$, the first buyer's entrance would be enough to drive the second and the third buyers out of the auction game, which is the meaning of part (2.c) in Proposition 5.

Figure 4 illustrates the equilibrium strategies when cost c is small, i.e. $c \in (0, c_1)$. It is easy to understand it if we just ignore the third dimension v_3 , then it reduces to what we have seen in Figure 1, which is actually a cross section plane to a cubic. The problem is that now these four areas of Figure 1 are equivalent to four cuboids in three-buyer environment. Since the third buyer has four possible signals, she has to decide four counterpart critical points. Each possible signal of buyer 3 represents one of the four cuboids. In Figure 4, the thick blue lines (or blue plane) represent the cutoff point of buyer 1. The unevenly dashed green lines (or green planes) refer to the second buyer's two cutoff values. And the four evenly dashed red planes demonstrate the four critical points for the third buyer.

Note that in general we cannot rule out the possibility of multiple solutions for the equation system in part (2.a) in Proposition 5 when the participation cost is small, i.e. $c \in (0, c_1)$. The system of equations is highly nonlinear, which does not mathematically promise a unique solution for the underlying auction game. Because there is no special requirement for the off-equilibrium path belief for buyers, especially those followers in the sequential decision process. As in the usual situations, a stronger equilibrium concept, the perfect Bayesian Nash equilibrium (PBE) may be not sufficient to select one equilibrium and eliminate the others. Since here followers only observe the formers' participation other than valuation types, it does not restrict the buyers' beliefs on the opponents' valuation types seriously on the off-equilibrium path. Under a stronger selection rule, namely, the intuitive criterion by Cho and Kreps (1987), the uniqueness would be met.

Suppose there are multiple solutions, i.e., $(x_1^{(3)}, x_{2P}^{(3)}, x_{3PN}^{(3)}, x_{3PP}^{(3)})$ and $(x_1'^{(3)}, x_{2P}'^{(3)}, x_{3PN}'^{(3)}, x_{3PP}'^{(3)})$ are two groups of solutions for the given cost $c \in (0, c_1)$. If $x_1^{(3)} = x_1'^{(3)}$, then the system of equations implies that the other six cutoff points must be equal pairwise, then the two solutions are exactly the same. Without loss of generality, let $x_1^{(3)} < x_1'^{(3)}$, then definitely the type- $x_1'^{(3)}$ buyer 1 can get positive surplus by playing the equilibrium strategies with the first profile of cutoff points, but she gets zero if playing the equilibrium strategies with prime critical value profile. Since buyer 1 is the first mover, she can switch to the first equilibrium strategies by deviation, and other rational players would expect this correctly. Because the intuitive criterion requires that players should not expect other players to find some deviation to be equilibrium-dominated, and all players are sure of it. The argument shows that only the equilibrium which has the lowest cutoff point $x_1^{(3)}$ survives.

The equilibrium can be easily obtained with asymmetric buyers, just like Proposition 3 parallel to Proposition 1. Therefore, for our main focus it is omitted here. We now turn to the general n -buyer case.

The conditions that cutoff values should satisfy in three-buyer case can shed light on the equilibrium characterization for general n -buyer case. We first give some additional definitions for expressing the equilibrium results with n buyers in a suitable way. Given that buyer 1 participates in the auction, buyer i ($i > 1$) should observe one signal $s_i \in \{P\} \times \{P, N\}^{i-2}$, and this signal can recover all signals received by those buyers who attend the auction before i . Let $\Phi_i(s_i)$ be the set of buyers who have entered into the auction when buyer i 's signal is $s_i \in \{P\} \times \{P, N\}^{i-2}$, and denote the counterpart signal received by buyer $j \in \Phi_i(s_i)$ as $s_j^*(s_i)$ which is recovered from s_i . Among those buyers $j \in \Phi_i(s_i)$, the buyer who attends the auction last before i is denoted by $j_0(s_i)$. The critical value of this buyer $j_0(s_i)$ plays a key role in specifying the condition for the cutoff strategy for buyer i receiving a signal s_i , since buyer $j_0(s_i)$ is on average the strongest opponent for buyer i regardless of the later buyers for the time being. Set Υ_i as the set of buyers who have made entrance decisions after i . Conditional on s_i and the event that any buyer $k \in \Upsilon_i$ does not participate in the auction, the counterpart signal received by those buyers $k \in \Upsilon_i$ is denoted by $s_k^*(s_i)$.

If there is no participation cost, namely, $c = 0$, all buyers will participate in the auction regardless of their values. So the corresponding critical values are $x_{i,s_i}^{(n)} = \underline{v}$ for all i and all $s_i \in \{P, N\}^{i-1}$. Then all buyers' critical values are in the range of (\underline{v}, \bar{v}) for sufficiently small cost c , since all critical values are continuous functions of the cost c .

Now we are ready to state the proposition summarizing an equilibrium with n potential buyers.

Proposition 6 *Suppose the participation cost is sufficiently small. In equilibrium, the total $2^n - 1$ cutoff points can be classified into two categories:*

- (1). *if the first buyer does not participate, this reduces to the $(n - 1)$ -buyer case. The $2^{n-1} - 1$ cutoff points, $x_{i,\{N,\hat{s}_i\}}^{(n)}$ for $i = 2, \dots, n$ and $\hat{s}_i \in \{P, N\}^{i-2}$, are given by*

$$x_{i,\{N,\hat{s}_i\}}^{(n)} = x_{i-1,\hat{s}_i}^{(n-1)}. \quad (9)$$

- (2). *if the first buyer participates, which is the case that corresponds to the other 2^{n-1} cutoff points, $x_1^{(n)}$ and $x_{i,s_i}^{(n)}$ for $i = 2, \dots, n$ and $s_i \in \{P\} \times \{P, N\}^{i-2}$, the zero expected payoff*

conditions that define those critical values would be

$$(x_{i,s_i}^{(n)} - \underline{v}) \prod_{k \in \Upsilon_i} F(x_{k,s_k^*}^{(n)}) = c, \text{ for } \Phi_i(s_i) = \emptyset; \quad (10a)$$

$$\frac{1}{\prod_{j \in \Phi_i(s_i)} [1 - F(x_{j,s_j^*}^{(n)})]} \int_{x_{j_0,s_{j_0}}^{(n)}}^{x_{i,s_i}^{(n)}} \prod_{j \in \Phi_i(s_i)} (F(v) - F(x_{j,s_j^*}^{(n)})) dv = c, \text{ for } \Upsilon_i = \emptyset; \quad (10b)$$

$$\frac{\prod_{k \in \Upsilon_i} F(x_{k,s_k^*}^{(n)})}{\prod_{j \in \Phi_i(s_i)} [1 - F(x_{j,s_j^*}^{(n)})]} \int_{x_{j_0,s_{j_0}}^{(n)}}^{x_{i,s_i}^{(n)}} \prod_{j \in \Phi_i(s_i)} (F(v) - F(x_{j,s_j^*}^{(n)})) dv = c, \text{ otherwise}; \quad (10c)$$

with monotonic constraints $x_{i,s_i}^{(n)} > x_{j_1,s_{j_1}^*}^{(n)} > x_{j_2,s_{j_2}^*}^{(n)}$ if $j_1 > j_2$, all $j_1, j_2 \in \Phi_i(s_i)$.

Remark 5 By assumption, this proposition does not describe equilibrium strategies for all possible values of participation cost c . Actually, a complete investigation needs to classify the region of participation cost into several parts, which is implicitly given by some other groups of equations that are reduced from conditions in part (2) of the Proposition 6. Hence this proposition provides a basic description instead of a perfect characterization.

In our sequential participation environment, each buyer can participate or not participate in the auction, therefore there are two subgames rooted from each buyer's given signal or information set in standard game theory terminology where she should move. Since the first buyer does not have any information other than prior belief, we can regard she has one information set \emptyset . Therefore, every buyer i has 2^{i-1} possible information sets, or every buyer has to specify 2^{i-1} parameters in total, one for each information set. Thus, there are overall $2^n - 1$ cutoff points to be determined in equilibrium. It seems to be a demanding task to work out. However, it is not so difficult to derive all the conditions.

If the first buyer does not participate, the second buyer would behave as if she were the first buyer and there were only $n - 1$ possible buyers. Hence in this subcase, the total $2^{n-1} - 1$ cutoff values are exactly the same as the $(n - 1)$ -buyer case, which is just what part (1) of the Proposition 6 says.

On the other hand if the first buyer participates, she would send a P signal to all the followers. Together with the first buyer's critical value $x_1^{(n)}$, there are 2^{n-1} parameters to be determined in this subcase. Since all conditions are concerning those buyers who have exactly critical values in hand, we only consider those buyers. Conditional on the buyer i 's signal $s_i \in \{P\} \times \{P, N\}^{i-2}$,¹² if buyer i participates, her value $x_{i,s_i}^{(n)}$ should be larger than all the critical values of those buyers

¹²Note that $s_1 \in \emptyset$ and $s_2 \in \{P\} \times \emptyset$ in this subcase.

who have entered into the auctions before her and she should also expect she can only win against those followers who do not participate. The term in the numerator of the left hand side of equation (10c) other than the integration represents the probability of the event that those buyers after i do not participate conditional on s_i . The other parts of the left hand side of equation (10c) refer to the expected profit by winning against those buyers participating before i conditional on the received signal s_i . The overall profit should just cover the participation cost c , which yields condition (10c). Now it is easy to understand equation (10a) and (10b) since they are just special cases, where there are no buyers participating before i for (10a) and there are no potential buyers participating after i for (10b).

4 Who wishes to go first?

In the previous sequential participation model, the sequence of entrance is predetermined instead of being part of the equilibrium strategy, therefore a natural question one would ask would be who wishes to go first. That is, would the leader get higher payoff if she were the follower, or would the follower be likely to earn more surplus if she switched to being the leader? The answer might rely on when you ask buyer this question, i.e., in *ex ante* stage or *interim* stage. Here *ex ante* stage refers to the time when buyer does not know her own valuation and *interim* stage refers to the time when buyer knows her own valuation but has not observed any actions of her opponent(s). We will discuss this problem in this section, but not trying to endogenize the order of participation in our sequential participation auction game.

We consider the setting with two buyers. If the two buyers are symmetric, the expected payoff in the unique equilibrium would be sufficient for evaluating the buyers' incentives to switch between the roles of leader and follower.¹³ Let $s_i(v_i)$ be the interim expected equilibrium payoff of buyer i , which can be obtained in the following way.

- The payoff $s_1(v_1)$ is zero if $\underline{v} \leq v_1 < x_1$ since the leader with value in this range will not participate. When $x_1 \leq v_1 \leq x_{2P}$, the leader incurs a cost c to participate, and wins only if the follower does not participate after observing leader's entrance, and this event occurs with probability $F(x_{2P})$. Conditional on winning, the leader just needs to pay the reservation price to get the object. Therefore, it yields the payoff $F(x_{2P})(v_1 - \underline{v}) - c$ for $v_1 \in [x_1, x_{2P}]$. Given $x_{2P} < v_1 \leq \bar{v}$, the leader gets the object at reservation price if the follower does not participate, which occurs with probability $F(x_{2P})$. Otherwise she wins only if the follower has value in the range (x_{2P}, v_1) , which occurs with probability

¹³With asymmetric buyers, since the equilibrium depends on which buyer is the leader, it is necessary to evaluate the payoff for two buyers in both equilibria.

$F(v_1) - F(x_{2P})$, and her expected payment for the object would be $E_{v_2}[v_2|x_{2P} < v_2 < v_1]$. Together the payoff would be $F(x_{2P})(v_1 - \underline{v}) + (F(v_1) - F(x_{2P}))(v_1 - E_{v_2}[v_2|x_{2P} < v_2 < v_1]) - c$ for $v_1 \in (x_{2P}, \bar{v}]$. Hence after rearranging terms, the function $s_1(v_1)$ is given by

$$s_1(v_1) = \begin{cases} 0, & \text{if } \underline{v} \leq v_1 < x_1; \\ F(x_{2P})(v_1 - \underline{v}) - c, & \text{if } x_1 \leq v_1 \leq x_{2P}; \\ F(x_{2P})(v_1 - \underline{v}) + \int_{x_{2P}}^{v_1} (F(y) - F(x_{2P}))dy - c, & \text{if } x_{2P} < v_1 \leq \bar{v}. \end{cases} \quad (11)$$

- The follower's payoff is also zero if $\underline{v} \leq v_2 < x_{2N}$, since she would never attend the auction regardless of the signal received due to the fact that $x_{2N} < x_1 < x_{2P}$. If the follower's value is drawn from $[x_{2N}, x_{2P}]$, she participates on observing a signal N and does not participate on observing a signal P . In the event that the leader does not participate which occurs with probability $F(x_1)$, the follower wins the object by paying the reservation price. This yields the payoff $F(x_1)(v_2 - \underline{v} - c)$ for $v_2 \in [x_{2N}, x_{2P}]$. If the follower's value is higher than x_{2P} , she participates for sure and can win in two events. One case is when the leader is absent, which occurs with probability $F(x_1)$, and she wins the object by paying reservation price. The other case is when the leader's value locates in the range (x_1, v_2) , which occurs with probability $F(v_2) - F(x_1)$, and the follower's payment is $E_{v_1}[v_1|x_1 < v_1 < v_2]$ conditional on winning. Therefore, the follower's payoff is given by $F(x_1)(v_2 - \underline{v}) + (F(v_2) - F(x_1))(v_2 - E_{v_1}[v_1|x_1 < v_1 < v_2]) - c$ for $v_2 \in (x_{2P}, \bar{v}]$. Thus, we have

$$s_2(v_2) = \begin{cases} 0, & \text{if } \underline{v} \leq v_2 < x_{2N}; \\ F(x_1)(v_2 - \underline{v} - c), & \text{if } x_{2N} \leq v_2 \leq x_{2P}; \\ F(x_1)(v_2 - \underline{v}) + \int_{x_1}^{v_2} (F(y) - F(x_1))dy - c, & \text{if } x_{2P} < v_2 \leq \bar{v}. \end{cases} \quad (12)$$

The payoffs are demonstrated in Figure 5.

Note that $s_i(v_i), i = 1, 2$, is piecewise linear for $v_i \in [\underline{v}, x_{2P}]$, and $s'_1(v) = s'_2(v) = F(v)$ for $v \in (x_{2P}, \bar{v})$. It is sufficient to investigate which one is larger for the values $s_1(x_{2P})$ and $s_2(x_{2P})$, in order to know buyers' incentives to switch. Simple algebra shows that $s_1(x_{2P}) > s_2(x_{2P})$.¹⁴ Now let $v^* \in (x_1, x_{2P})$ be such that $s_1(v^*) = s_2(v^*)$. Then immediately we have the following proposition

¹⁴This is because $s_1(x_{2P}) = F(x_{2P})(x_{2P} - \underline{v}) - c$ and $s_2(x_{2P}) = F(x_1)(x_{2P} - \underline{v} - c)$, the sign of the difference $s_1(x_{2P}) - s_2(x_{2P})$ can be easily determined by identity substitution for the term $c(1 - F(x_1))$ from equation (3b). And the sign is positive.

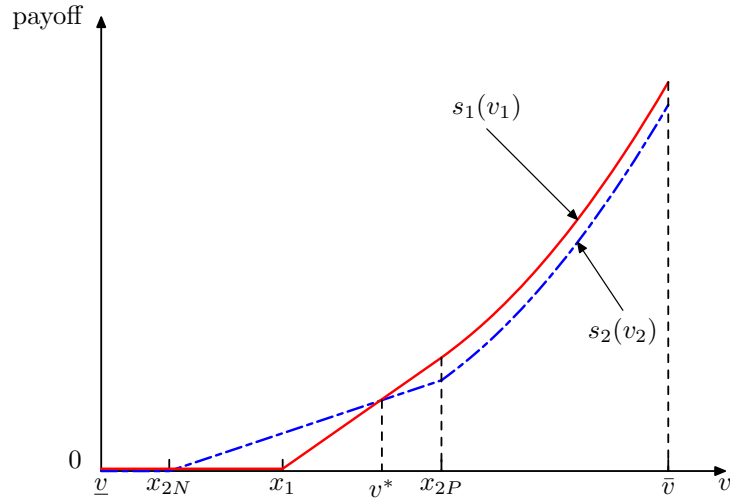

Figure 5: The Payoffs for Two Symmetric Buyers

Proposition 7 *Suppose $c \in (0, c_0)$ and there are two symmetric buyers. Then both buyers would prefer to be the follower if their values $v \in (x_{2N}, v^*)$, and prefer to be the leader if their values $v \in [v^*, \bar{v}]$, and they are indifferent between being the leader and the follower if $v \in [v, x_{2N}]$.*

Buyer always prefers being in the role that leads to higher payoff for her. When the value is too low, it is optimal to be outside, this is true for both the leader and the follower and there is no indifference between the two roles. If the value is moderate, i.e., $v \in (x_{2N}, x_1)$, the leader would not participate but the follower would participate conditional on receiving a signal N , which occurs with positive probability. Since entrance can promise positive expected payoff, buyer surely prefers to be the follower in this case. Also note that expected payoff is continuous in one's own value, so this dominance relationship should hold for some interval containing any $v \in (x_{2N}, x_1)$, and precisely the interval is (x_{2N}, v^*) . For high value close to \bar{v} , the leader meets with an absent follower with high probability, i.e., $F(x_{2P})$, and wins the auction at reservation price, while the follower meets with an absent leader only with probability $F(x_1)$. The event of meeting with an absent follower benefits the leader a lot. Therefore, the leader's payoff dominates the follower's for high values.

But on average, the buyer's *ex ante* expected payoff does not have a substantiated dominance relationship yet, since the answer to this question relies on both the c.d.f and size of the cost c , which cannot be classified in a simple way.

5 Comparison with Simultaneous Participation

Our sequential participation auction game may be regarded as a Stackelberg version for auction competition while the simultaneous participation appears to be a Cournot version for auction competition. Therefore, it is natural to compare the model analyzed here with those simultaneous ones.

We make a comparison by focusing on the symmetric buyers. Suppose there are n potential symmetric buyers who compete for an object in our basic settings. Then in Bayesian equilibrium, each buyer would use a cutoff strategy, and the buyer participates if and only if her value exceeds some critical point $y^{(n)}$, which requires every buyer have the same cutoff point.¹⁵ Then the equilibrium is determined by the following equation,

$$(y^{(n)} - \underline{v})[F(y^{(n)})]^{n-1} = c. \quad (13)$$

Note that the buyer with critical value $y^{(n)}$ participates in the auction and wins against her opponents only if all other buyers do not enter, which occurs with probability $[F(y^{(n)})]^{n-1}$.

We first determine the upper bound of the participation cost which can drive some buyers out of the auction. In other words, if participation cost reaches this bound, there exists a potential buyer who would never participate in the auction regardless of what her valuation is. Let $y^{(n)} = \bar{v}$, equation (13) tells that $c = \Delta v$. Note that no matter how many potential buyers, the upper bound of the cost in simultaneous participation models does not change. While in our sequential model, this bound turns to be smaller as the number of buyers increases. For instance, it is c_0 for two-buyer environment from Proposition 1, and it becomes c_1 ($c_1 < c_0$) when there are three buyers from Proposition 5. If there exists some buyer who would never participate in the auction based on her received information regardless of her values, we call this buyer is *driven-out*, and we say the cost at this level has *driven-out effect*. If there exist more such buyers in one environment than in another, the driven-out effect is said to be stronger in the former circumstance. Hence, we get

Proposition 8 *Suppose the buyers are symmetric. The driven-out effect caused by the participation cost is the same as the number of buyers increases in second price auction game with simultaneous participation. However, the driven-out effect becomes stronger as the number of buyers increases in second price auction game with sequential participation. For a given participation cost, the driven-out effect is more likely to happen in second price auction game with sequential participation than in second price auction with simultaneous participation.*

¹⁵Tan and Yilankaya (2006) show that if $F(\cdot)$ is concave, this equilibrium is unique.

The following example illustrates the result of the proposition in the case of uniform distribution.

Example 1 *Let $\underline{v} = 0$, $\bar{v} = 1$, $F(v) = v$. Then in sequential participation model, the critical cost at which the driven out effect occurs is $c_0 = 0.3333$ in two-buyer setting, $c_1 = 0.1295$ in three-buyer setting and $c_2 = 0.0568$ in four-buyer setting, while the corresponding critical cost is always $\Delta v = 1$ in simultaneous participation model.¹⁶*

This relates to our primary concern about the buyers' information on participation. Now it is clear that this information can prevent potential buyers from participating in the auction when there exists participation cost. Actually, a small participation cost can deter the last buyer's entrance when the number of buyers is large. Example 1 says a cost $c = 0.0568$ (approximately 11% of the mean valuation) is enough to drive out a buyer when there are only four buyers in a setting with uniform distribution. From this view, the simultaneous participation model might not be desirable to describe the realistic situation, since it ignores the *driven-out effect* in the participation decision which influences the competition itself in auctions.

6 Conclusion

In this paper, we explore the insights of sequential participation in second price auction when there exists participation cost. We first analyze the existence and uniqueness of cutoff-strategy equilibrium with two buyers in both symmetric and asymmetric settings. Then we extend the equilibrium analysis to the environment with three buyers, and provide the equilibrium characterization results for general n -buyer case. We also show the monotonicity of the critical values with respect to participation cost in two-buyer settings. If two buyers are symmetric, the follower's cutoff value is increasing as participation cost increases, this is also true for the leader if c.d.f. $F(\cdot)$ is concave. When two buyers are asymmetric, the monotonicity of cutoff point for the follower remains true, and the monotonicity would hold true for the leader under concavity of $F_1(\cdot)$ and a dominance condition in reverse hazard rate.

We also discuss the incentives of two symmetric buyers over the order of participation, without endogenizing the sequence of participation. It is shown that the valuation support can be divided into three connected regions. In the lower region buyers are indifferent between being a leader and a follower, but they prefer to be the follower if their values are drawn from the middle region, and prefer to be the leader when their values locate in the high region. By

¹⁶ c_0 is obtained from equation (2), c_1 is solved from equation system (6), and c_2 in four-buyer setting is achieved from equation system in Proposition 6 part (2) with $x_{4PP}^{(4)} = 1$ and $c = c_2$.

defining the *driven-out effect*, we find that sequential participation drives out buyers more easily than simultaneous participation environment, which means the simultaneous participation model might not be desirable to describe the real situations if buyers can observe others' participation and participation is costly.

An interesting open question is how the equilibrium looks like if the order of participation is not predeterminate, but is part of the equilibrium. This requires an additional stage at which the sequence of entrance is negotiated. Such specification can lead to another problem: the negotiation itself and participation decision both are signals that convey valuation types. Therefore, the new model needs to identify the effects of different signal types, which remains to be investigated in future research.

Appendix: Proofs

PROOF OF PROPOSITION 1: Note that the buyer with critical value should be indifferent between participating in auction and not participating, namely getting zero expected payoff; otherwise the buyer with value slightly less than the critical level would find it optimal to attend the auction, which violates the definition of cutoff points.

Obviously, the follower is able to get the object by paying a reservation price \underline{v} and bearing a participation cost when she observes the leader does not participate. Therefore, the critical value x_{2N} satisfies $x_{2N} = c + \underline{v}$.

It is also evident to show that the follower with signal P has higher critical threshold than the leader's. This is because the leader regards her opponent—the follower's value drawn from $[\underline{v}, \bar{v}]$, and the follower with signal P regards her opponent—the leader's value drawn from truncated support $[x_1, \bar{v}]$. That is, the follower with signal P confronts a stronger opponent than the leader does. Hence, it yields $x_{2P} > x_1$. Consider the type- x_1 leader, she can win against her opponent with value less than x_{2P} at reservation price, with corresponding winning probability $F(x_{2P})$, by incurring a participation cost if she participates. Then the leader's indifference condition reads

$$(x_1 - \underline{v})F(x_{2P}) - c = 0,$$

which gives equation (3a).

We then consider the type- x_{2P} follower's indifference condition. Conditional on the signal P received by the follower, the leader's value is distributed over $[x_1, \bar{v}]$. Therefore if the follower with value x_{2P} participates, she can win against her opponent who has value drawn from $[x_1, x_{2P}]$, with corresponding winning probability $\frac{F(x_{2P}) - F(x_1)}{1 - F(x_1)}$. The expected price would be $\int_{x_1}^{x_{2P}} v \frac{f(v)}{F(x_{2P}) - F(x_1)} dv$ conditional on her winning. In turn this yields type- x_{2P} follower's indifference condition which reads

$$\frac{F(x_{2P}) - F(x_1)}{1 - F(x_1)} \left[x_{2P} - \int_{x_1}^{x_{2P}} v \frac{f(v)}{F(x_{2P}) - F(x_1)} dv \right] - c = 0.$$

Integration by parts and rearranging terms gives equation (3b).

It remains to show the two-equation system has solution and the solution is unique. To begin with, we define a function $\phi(\cdot)$ in x_1 as:

$$\phi(x_1) = \frac{1}{1 - F(x_1)} \int_{x_1}^{x_{2P}(x_1)} (F(v) - F(x_1)) dv - c,$$

where the upper bound of integration $x_{2P}(x_1)$ is a function of x_1 implicitly defined by (3a),

note that $x_{2P}(\cdot)$ is differentiable and strictly decreasing since $F(\cdot)$ is differentiable and strictly increasing. Differentiating $\phi(x_1)$ with respect to x_1 yields

$$\begin{aligned}\phi'(x_1) &= \frac{1}{(1-F(x_1))^2} \left\{ \left[(F(x_{2P}) - F(x_1)) \frac{\partial x_{2P}}{\partial x_1} - f(x_1)(x_{2P} - x_1) \right] (1 - F(x_1)) \right. \\ &\quad \left. + f(x_1) \int_{x_1}^{x_{2P}} (F(v) - F(x_1)) dv \right\} \\ &< \frac{1}{(1-F(x_1))^2} (1 - F(x_1)) (F(x_{2P}) - F(x_1)) \frac{\partial x_{2P}}{\partial x_1} \\ &< 0,\end{aligned}$$

which says $\phi(\cdot)$ is monotonically decreasing. Given the possible maximum value of $x_1 = x_{2P}$, $\phi(x_{2P}) = -c < 0$. The possible minimum value x_1 is $c + \underline{v}$, for the meaningful x_{2P} would not exceed the upper bound of support \bar{v} . Therefore, we just need to show $\phi(c + \underline{v}) \geq 0$, and the existence and uniqueness of solutions both would follow. Note that

$$\phi(c + \underline{v}) = \frac{1}{1 - F(c + \underline{v})} \int_{c + \underline{v}}^{\bar{v}} (F(v) - F(c + \underline{v})) dv - c,$$

where $x_{2P}(c + \underline{v}) = \bar{v}$. Simple algebra shows $\frac{\partial}{\partial c} \phi(c + \underline{v}) < -1$, $\phi(c + \underline{v})|_{c=0} = \int_{\underline{v}}^{\bar{v}} F(v) dv > 0$ and $\lim_{c \rightarrow (\Delta v)^-} \phi(c + \underline{v}) = -\Delta v$. It tells that the equation $\phi(c + \underline{v}) = 0$ with unknown parameter c has a unique solution $c_0 \in (0, \Delta v)$, which is just the definition of c_0 . By the monotonicity of $\phi(c + \underline{v})$ in c , it follows that $\phi(c + \underline{v}) \geq 0$ for $c \in (0, c_0)$. This completes the proof. \square

PROOF OF PROPOSITION 2: Since $x_{2N} = c + \underline{v}$, the monotonicity for x_{2N} is immediate. Let x_1 and x_{2P} be two functions of c implicitly defined by equations (3a) and (3b) in Proposition 2. Differentiating these two equations with respect to c , we then get

$$\begin{aligned}F(x_{2P}) \frac{\partial x_1}{\partial c} + f(x_{2P})(x_1 - \underline{v}) \cdot \frac{\partial x_{2P}}{\partial c} &= 1; \\ -\frac{f(x_1) \int_{x_1}^{x_{2P}} [1 - F(v)] dv}{[1 - F(x_1)]^2} \cdot \frac{\partial x_1}{\partial c} + \frac{F(x_{2P}) - F(x_1)}{1 - F(x_1)} \cdot \frac{\partial x_{2P}}{\partial c} &= 1.\end{aligned}$$

Solving for $\frac{\partial x_1}{\partial c}$ and $\frac{\partial x_{2P}}{\partial c}$ yields

$$\frac{\partial x_1}{\partial c} = \frac{1}{\Omega} \begin{vmatrix} 1 & f(x_{2P})(x_1 - \underline{v}) \\ 1 & \frac{F(x_{2P}) - F(x_1)}{1 - F(x_1)} \end{vmatrix}, \quad \frac{\partial x_{2P}}{\partial c} = \frac{1}{\Omega} \begin{vmatrix} F(x_{2P}) & 1 \\ -\frac{f(x_1) \int_{x_1}^{x_{2P}} [1 - F(v)] dv}{[1 - F(x_1)]^2} & 1 \end{vmatrix} > 0,$$

where

$$\Omega = \left| \begin{array}{cc} F(x_{2P}) & f(x_{2P})(x_1 - \underline{v}) \\ -\frac{f(x_1) \int_{x_1}^{x_{2P}} [1-F(v)] dv}{[1-F(x_1)]^2} & \frac{F(x_{2P})-F(x_1)}{1-F(x_1)} \end{array} \right| > 0.$$

Therefore, the monotonicity for x_1 holds if the numerator $N_1 = \frac{F(x_{2P})-F(x_1)}{1-F(x_1)} - f(x_{2P})(x_1 - \underline{v})$ is positive.

Now assume $F(\cdot)$ is concave. By substituting equations (3a) and (3b) into this term, we have

$$\begin{aligned} N_1 &= c \cdot \frac{F(x_{2P}) - F(x_1)}{\int_{x_1}^{x_{2P}} [F(v) - F(x_1)] dv} - c \cdot \frac{f(x_{2P})}{F(x_{2P})} \\ &= c \left[\frac{f(\hat{v})(x_{2P} - x_1)}{[F(\tilde{v}) - F(x_1)](x_{2P} - x_1)} - \frac{f(x_{2P})}{F(x_{2P})} \right] \\ &> c \left[\frac{f(\hat{v})}{F(x_{2P})} - \frac{f(x_{2P})}{F(x_{2P})} \right] \geq 0, \end{aligned}$$

where the second line follows by applying the mean value theorem to the numerator and applying mean value theorem for integration to the denominator with $\hat{v}, \tilde{v} \in (x_1, x_{2P})$, and the positiveness of the third line follows if we promise the concavity of $F(\cdot)$ which means $f(\cdot)$ is a non-increasing function. This completes the proof. \square

PROOF OF PROPOSITION 4: The argument is exactly the same as the proof of Proposition 2. After differentiating both sides of equations (5a) and (5b) with respect to c by regarding x_1 and x_{2P} as implicit functions of c , we get

$$\frac{\partial x_1}{\partial c} = \frac{1}{\Omega_a} \left| \begin{array}{cc} 1 & f_2(x_{2P})(x_1 - \underline{v}) \\ 1 & \frac{F_1(x_{2P})-F_1(x_1)}{1-F_1(x_1)} \end{array} \right|, \quad \frac{\partial x_{2P}}{\partial c} = \frac{1}{\Omega_a} \left| \begin{array}{cc} F_2(x_{2P}) & 1 \\ -\frac{f_1(x_1) \int_{x_1}^{x_{2P}} [1-F_1(v)] dv}{[1-F_1(x_1)]^2} & 1 \end{array} \right| > 0,$$

where

$$\Omega_a = \left| \begin{array}{cc} F_2(x_{2P}) & f_2(x_{2P})(x_1 - \underline{v}) \\ -\frac{f_1(x_1) \int_{x_1}^{x_{2P}} [1-F_1(v)] dv}{[1-F_1(x_1)]^2} & \frac{F_1(x_{2P})-F_1(x_1)}{1-F_1(x_1)} \end{array} \right| > 0.$$

By substituting, we get

$$\begin{aligned}
\frac{\partial x_1}{\partial c} &= \frac{1}{\Omega_a} \left[\frac{F_1(x_{2P}) - F_1(x_1)}{1 - F_1(x_1)} - f_2(x_{2P})(x_1 - \underline{v}) \right] \\
&= \frac{1}{\Omega_a} \left[c \cdot \frac{F_1(x_{2P}) - F_1(x_1)}{\int_{x_1}^{x_{2P}} [F_1(v) - F_1(x_1)] dv} - c \cdot \frac{f_2(x_{2P})}{F_2(x_{2P})} \right] \\
&= \frac{c}{\Omega_a} \left[\frac{f_1(v')(x_{2P} - x_1)}{[F_1(v'') - F_1(x_1)](x_{2P} - x_1)} - \frac{f_2(x_{2P})}{F_2(x_{2P})} \right] \\
&> \frac{c}{\Omega_a} \left[\frac{f_1(x_{2P})}{F_1(x_{2P})} - \frac{f_2(x_{2P})}{F_2(x_{2P})} \right] \geq 0;
\end{aligned}$$

where the third line follows by mean value theorem and mean value theorem for integration with $v', v'' \in (x_1, x_{2P})$, the fourth line follows by concavity of $F_1(\cdot)$, and the last inequality follows by the dominance in terms of reverse hazard rate. The proof is complete. \square

PROOF OF LEMMA 1: For convenience, we restate the equations that define c_1 and two critical values $x_{2P}^{*(3)}$ and $x_1^{*(3)}$ as follows.

$$(x_1^{*(3)} - \underline{v})[F(x_{2P}^{*(3)})]^2 = c_1; \quad (14a)$$

$$\frac{1}{1 - F(x_1^{*(3)})} \int_{x_1^{*(3)}}^{x_{2P}^{*(3)}} (F(v) - F(x_1^{*(3)})) dv = c_1; \quad (14b)$$

$$\frac{1}{[1 - F(x_1^{*(3)})][1 - F(x_{2P}^{*(3)})]} \int_{x_{2P}^{*(3)}}^{\bar{v}} [F(v) - F(x_{2P}^{*(3)})][F(v) - F(x_1^{*(3)})] dv = c_1. \quad (14c)$$

We now prove c_1 is well-defined through the above equations. To see this, given $c_1 \in (0, c_0)$, the first two equations define two continuous functions $x_1^{*(3)}(c_1)$ and $x_{2P}^{*(3)}(c_1)$. Let

$$\lambda(c_1) = \frac{1}{[1 - F(x_1^{*(3)})][1 - F(x_{2P}^{*(3)})]} \int_{x_{2P}^{*(3)}}^{\bar{v}} [F(v) - F(x_{2P}^{*(3)})][F(v) - F(x_1^{*(3)})] dv - c_1,$$

which can be regarded as a continuous function in c_1 . Since $x_1^{*(3)}(0) = x_{2P}^{*(3)}(0) = \underline{v}$ for $c_1 = 0$ and $x_1^{*(3)}(c_0) = c_0 + \underline{v}$, $x_{2P}^{*(3)}(c_0) = \bar{v}$ for $c_1 = c_0$, we have $\lambda(0) = \int_{\underline{v}}^{\bar{v}} F^2(v) dv > 0$ and $\lambda(c_0) = -c_0 < 0$. By continuity of $\lambda(\cdot)$, there exists $c_1 \in (0, c_0)$ such that $\lambda(c_1) = 0$.

It remains to show that c_1 is uniquely determined by these equations, which would be true

if $\lambda(\cdot)$ is monotonically decreasing. We now show the monotonicity of $\lambda(\cdot)$. By chain rule

$$\begin{aligned} \frac{d\lambda}{dc_1} &= \frac{\partial\lambda}{\partial x_1^{*(3)}} \cdot \frac{\partial x_1^{*(3)}}{\partial c_1} + \frac{\partial\lambda}{\partial x_{2P}^{*(3)}} \cdot \frac{\partial x_{2P}^{*(3)}}{\partial c_1} + \frac{\partial\lambda}{\partial c_1} \\ &= -\frac{f(x_1^{*(3)}) \int_{x_{2P}^{*(3)}}^{\bar{v}} [1-F(v)][F(v)-F(x_{2P}^{*(3)})]dv}{[1-F(x_1^{*(3)})]^2 [1-F(x_{2P}^{*(3)})]} \cdot \frac{\partial x_1^{*(3)}}{\partial c_1} \\ &\quad -\frac{f(x_{2P}^{*(3)}) \int_{x_1^{*(3)}}^{\bar{v}} [1-F(v)][F(v)-F(x_1^{*(3)})]dv}{[1-F(x_1^{*(3)})][1-F(x_{2P}^{*(3)})]^2} \cdot \frac{\partial x_{2P}^{*(3)}}{\partial c_1} - 1. \end{aligned}$$

Note that here $\frac{\partial\lambda}{\partial x_1^{*(3)}}$ and $\frac{\partial\lambda}{\partial x_{2P}^{*(3)}}$ both are negative. Using the same method as in the proof of Proposition 2, differentiating equations (14a) and (14b) with respect to c_1 yields

$$\begin{aligned} F^2(x_{2P}^{*(3)}) \frac{\partial x_1^{*(3)}}{\partial c_1} + 2F(x_{2P}^{*(3)})f(x_{2P}^{*(3)})(x_1^{*(3)} - \underline{v}) \cdot \frac{\partial x_{2P}^{*(3)}}{\partial c_1} &= 1; \\ -\frac{f(x_1^{*(3)}) \int_{x_1^{*(3)}}^{x_{2P}^{*(3)}} [1-F(v)]dv}{[1-F(x_1^{*(3)})]^2} \cdot \frac{\partial x_1^{*(3)}}{\partial c_1} + \frac{F(x_{2P}^{*(3)}) - F(x_1^{*(3)})}{1-F(x_1^{*(3)})} \cdot \frac{\partial x_{2P}^{*(3)}}{\partial c_1} &= 1. \end{aligned}$$

Therefore, we have

$$\begin{aligned} \frac{\partial x_1^{*(3)}}{\partial c_1} &= \frac{1}{\Omega_2} \begin{vmatrix} 1 & 2F(x_{2P}^{*(3)})f(x_{2P}^{*(3)})(x_1^{*(3)} - \underline{v}) \\ 1 & \frac{F(x_{2P}^{*(3)}) - F(x_1^{*(3)})}{1-F(x_1^{*(3)})} \end{vmatrix}, \\ \frac{\partial x_{2P}^{*(3)}}{\partial c_1} &= \frac{1}{\Omega_2} \begin{vmatrix} F^2(x_{2P}^{*(3)}) & 1 \\ \frac{f(x_1^{*(3)}) \int_{x_1^{*(3)}}^{x_{2P}^{*(3)}} [1-F(v)]dv}{[1-F(x_1^{*(3)})]^2} & 1 \end{vmatrix} = \frac{F^2(x_{2P}^{*(3)})}{\Omega_2} + \frac{f(x_1^{*(3)}) \int_{x_1^{*(3)}}^{x_{2P}^{*(3)}} [1-F(v)]dv}{\Omega_2 [1-F(x_1^{*(3)})]^2} > 0, \end{aligned}$$

where

$$\Omega_2 = \begin{vmatrix} F^2(x_{2P}^{*(3)}) & 2F(x_{2P}^{*(3)})f(x_{2P}^{*(3)})(x_1^{*(3)} - \underline{v}) \\ \frac{f(x_1^{*(3)}) \int_{x_1^{*(3)}}^{x_{2P}^{*(3)}} [1-F(v)]dv}{[1-F(x_1^{*(3)})]^2} & \frac{F(x_{2P}^{*(3)}) - F(x_1^{*(3)})}{1-F(x_1^{*(3)})} \end{vmatrix} > 0.$$

Note that substituting equations (14a) and (14b) into the numerator of $\frac{\partial x_1^{*(3)}}{\partial c_1}$ which here is

denoted as N_2 , it yields

$$\begin{aligned}
N_2 &= \frac{F(x_{2P}^{*(3)}) - F(x_1^{*(3)})}{1 - F(x_1^{*(3)})} - 2F(x_{2P}^{*(3)})f(x_{2P}^{*(3)})(x_1^{*(3)} - v) \\
&= c_1 \left[\frac{F(x_{2P}^{*(3)}) - F(x_1^{*(3)})}{\int_{x_1^{*(3)}}^{x_{2P}^{*(3)}} [F(v) - F(x_1^{*(3)})] dv} - 2 \frac{f(x_{2P}^{*(3)})}{F(x_{2P}^{*(3)})} \right] \\
&= c_1 \left[\frac{F(x_{2P}^{*(3)}) - F(x_1^{*(3)})}{\int_{x_1^{*(3)}}^{x_{2P}^{*(3)}} [F(v) - F(x_1^{*(3)})] dv} - \frac{f(x_{2P}^{*(3)})}{F(x_{2P}^{*(3)})} \right] - c_1 \frac{f(x_{2P}^{*(3)})}{F(x_{2P}^{*(3)})}.
\end{aligned}$$

The same reasoning as in the argument of Proposition 2 shows that the term in the brackets in the last line is positive when $F(\cdot)$ is concave. It implies that the only positive term in the expression of $\frac{d\lambda}{dc_1}$ is $-\frac{1}{\Omega_2} \cdot \frac{c_1 f(x_{2P}^{*(3)})}{F(x_{2P}^{*(3)})} \cdot \frac{\partial \lambda}{\partial x_1^{*(3)}}$. If this positive term is balanced by other terms, the fact that $\frac{d\lambda}{dc_1} < 0$ is promised. We only use the second part of $\frac{\partial x_{2P}^{*(3)}}{\partial c_1}$ to pin down this term. That is,

$$\begin{aligned}
&-\frac{1}{\Omega_2} \cdot \frac{c_1 f(x_{2P}^{*(3)})}{F(x_{2P}^{*(3)})} \cdot \frac{\partial \lambda}{\partial x_1^{*(3)}} + \frac{f(x_1^{*(3)}) \int_{x_1^{*(3)}}^{x_{2P}^{*(3)}} [1 - F(v)] dv}{\Omega_2 [1 - F(x_1^{*(3)})]^2} \cdot \frac{\partial \lambda}{\partial x_{2P}^{*(3)}} \\
&= \frac{f(x_1^{*(3)}) f(x_{2P}^{*(3)})}{\Omega_2 [1 - F(x_1^{*(3)})]^2 [1 - F(x_{2P}^{*(3)})]^2} \left[(x_1^{*(3)} - v) F(x_{2P}^{*(3)}) [1 - F(x_{2P}^{*(3)})] \right. \\
&\quad \left. \int_{x_{2P}^{*(3)}}^{\bar{v}} (1 - F(v))(F(v) - F(x_{2P}^{*(3)})) dv - \frac{\int_{x_1^{*(3)}}^{x_{2P}^{*(3)}} (1 - F(v)) dv}{1 - F(x_1^{*(3)})} \int_{x_{2P}^{*(3)}}^{\bar{v}} (1 - F(v))(F(v) - F(x_1^{*(3)})) dv \right] \\
&< \frac{f(x_1^{*(3)}) f(x_{2P}^{*(3)}) \int_{x_{2P}^{*(3)}}^{\bar{v}} (1 - F(v))(F(v) - F(x_1^{*(3)})) dv}{\Omega_2 [1 - F(x_1^{*(3)})]^2 [1 - F(x_{2P}^{*(3)})]^2} \cdot \chi_0,
\end{aligned}$$

where

$$\begin{aligned}
\chi_0 &= \left[(x_1^{*(3)} - v) F(x_{2P}^{*(3)}) [1 - F(x_{2P}^{*(3)})] - \frac{\int_{x_1^{*(3)}}^{x_{2P}^{*(3)}} (1 - F(v)) dv}{1 - F(x_1^{*(3)})} \right] \\
&= \frac{c_1}{F(x_{2P}^{*(3)})} \cdot [1 - F(x_{2P}^{*(3)})] - \frac{c_1 \cdot \int_{x_1^{*(3)}}^{x_{2P}^{*(3)}} (1 - F(v)) dv}{\int_{x_1^{*(3)}}^{x_{2P}^{*(3)}} (F(v) - F(x_1^{*(3)})) dv} \\
&= c_1 \left[\frac{1 - F(x_{2P}^{*(3)})}{F(x_{2P}^{*(3)})} - \frac{(1 - F(z_1))(x_{2P}^{*(3)} - x_1^{*(3)})}{(F(z_2) - F(x_1^{*(3)}))(x_{2P}^{*(3)} - x_1^{*(3)})} \right] \\
&< 0;
\end{aligned}$$

here the second line follows by identity substitution from equations (14a) and (14b), the third line follows by applying mean value theorem for integration, with $z_1, z_2 \in (x_1^{*(3)}, x_{2P}^{*(3)})$. Therefore, $\lambda(\cdot)$ is monotonic and c_1 is uniquely determined, and $c_1 < c_0$ is self-evident. This completes the proof. \square

PROOF OF PROPOSITION 5: If buyer 1 does not participate, it is evident that the situation for the second and the third buyers is the same as the two-buyer auction game, hence the critical points $x_{2N}^{(3)}, x_{3NP}^{(3)}, x_{3NN}^{(3)}$ in this subcase are completely characterized by Proposition 1, corresponding to x_1, x_{2P}, x_{2N} respectively. This yields part (1).

Now consider the case in which the first buyer participates in the auction, which relates to four critical points, $x_1^{(3)}$ for buyer 1, $x_{2P}^{(3)}$ for buyer 2, and $x_{3PN}^{(3)}$ and $x_{3PP}^{(3)}$ for buyer 3. Obviously, $x_1^{(3)} < x_{2P}^{(3)} < x_{3PP}^{(3)}$ and $x_1^{(3)} < x_{3PN}^{(3)} < x_{3PP}^{(3)}$, since on observing former buyers' entrance the later buyer has to win with positive probability and hence should own a higher critical point, to cover its participation cost.

Next we will specify the conditions that these critical points should satisfy by assuming no buyer would never participate in the auction regardless of her valuation.

We begin with the type- $x_1^{(3)}$ buyer 1. Again she must be indifferent between participating and not participating, i.e. participation yields her zero expected payoff. It is clear that if this type of buyer 1 participates, she can win only if the other two buyers are absent. Because on observing buyer 1's participation, either buyer 2 or buyer 3 participates or both participate, their values would be larger than $x_1^{(3)}$. Given buyer 1 participates, the absence of buyer 2, i.e., a buyer 2 with value less than $x_{2P}^{(3)}$, occurs with probability $F(x_{2P}^{(3)})$. Given that buyer 1's participation and buyer 2's absence, buyer 3 would not enter if her value is less than $x_{3PN}^{(3)}$, which occurs with probability $F(x_{3PN}^{(3)})$. Since values are independent, the zero-payoff condition reads

$$(x_1^{(3)} - \underline{v})F(x_{2P}^{(3)})F(x_{3PN}^{(3)}) = c,$$

which gives condition (7a).

Continue to consider buyer 2's decision on observing buyer 1's entrance. We are concerned about the buyer with critical value $x_{2P}^{(3)}$. Note that buyer 2 knows buyer 1 has value in the range $[x_1^{(3)}, \bar{v}]$. Again the type- $x_{2P}^{(3)}$ buyer 2 must get zero expected payoff by participation in auction. After attendance, she wins only if the third buyer does not enter, which occurs with probability $F(x_{3PP}^{(3)})$ since buyer 3 with value less than $x_{3PP}^{(3)}$ would not attend the auction conditional on observing buyer 1 and 2's participation. Provided the absence of buyer 3, the type- $x_{2P}^{(3)}$ buyer 2

can win only against buyer 1 with value in the range $[x_1^{(3)}, x_{2P}^{(3)}]$, with probability $\frac{F(x_{2P}^{(3)}) - F(x_1^{(3)})}{1 - F(x_1^{(3)})}$. Hence the total winning probability is $F(x_{3PP}^{(3)}) \cdot \frac{F(x_{2P}^{(3)}) - F(x_1^{(3)})}{1 - F(x_1^{(3)})}$. Conditional on winning, this buyer 2's expected payment for the object is $\int_{x_1^{(3)}}^{x_{2P}^{(3)}} v \frac{f(v)}{F(x_{2P}^{(3)}) - F(x_1^{(3)})} dv$. Then the indifference condition for type- $x_{2P}^{(3)}$ buyer 2 can be written as

$$F(x_{3PP}^{(3)}) \cdot \frac{F(x_{2P}^{(3)}) - F(x_1^{(3)})}{1 - F(x_1^{(3)})} \left[x_{2P}^{(3)} - \int_{x_1^{(3)}}^{x_{2P}^{(3)}} v \frac{f(v)}{F(x_{2P}^{(3)}) - F(x_1^{(3)})} dv \right] = c,$$

which yields the condition (7b) after integration by parts and rearranging terms.

We now turn to investigate the third buyer's problem and specify two conditions for two critical thresholds $x_{3PN}^{(3)}$ and $x_{3PP}^{(3)}$. First consider the case in which buyer 1 participates in the auction but buyer 2 does not, so buyer 3 observes a signal $s_3 = \{P, N\}$. It suffices to focus on buyer 3 with critical value $x_{3PN}^{(3)}$. This type- $x_{3PN}^{(3)}$ buyer 3 only has one opponent—a buyer 1 with value in the range $[x_1^{(3)}, \bar{v}]$, hence her winning probability is $\frac{F(x_{3PN}^{(3)}) - F(x_1^{(3)})}{1 - F(x_1^{(3)})}$ and her expected payment for the object turns to be $\int_{x_1^{(3)}}^{x_{3PN}^{(3)}} v \frac{f(v)}{F(x_{3PN}^{(3)}) - F(x_1^{(3)})} dv$ conditional on winning. Therefore, the zero-payoff condition becomes

$$\frac{F(x_{3PN}^{(3)}) - F(x_1^{(3)})}{1 - F(x_1^{(3)})} \left[x_{3PN}^{(3)} - \int_{x_1^{(3)}}^{x_{3PN}^{(3)}} v \frac{f(v)}{F(x_{3PN}^{(3)}) - F(x_1^{(3)})} dv \right] - c = 0,$$

which gives equation (7c), a reduced form of the above indifference condition.

It remains to define the indifference condition for buyer 3 with critical value $x_{3PP}^{(3)}$. Note that $x_{3PP}^{(3)} > x_{2P}^{(3)} > x_1^{(3)}$. Conditional on observing the participation of the former two buyers, if the type- $x_{3PP}^{(3)}$ buyer 3 attends the auction, she wins against those who have value less than her value $x_{3PP}^{(3)}$, i.e., buyer 1 with value in the range $[x_1^{(3)}, x_{3PP}^{(3)}]$ and buyer 2 with value in the range $[x_{2P}^{(3)}, x_{3PP}^{(3)}]$. Therefore, the winning probability for her is $\frac{F(x_{3PP}^{(3)}) - F(x_1^{(3)})}{1 - F(x_1^{(3)})} \cdot \frac{F(x_{3PP}^{(3)}) - F(x_{2P}^{(3)})}{1 - F(x_{2P}^{(3)})}$, the expected trading price would be the expected maximum value of buyer 1 and buyer 2, i.e., $E[\max\{v_1, v_2\} | x_1^{(3)} < v_1 < x_{3PP}^{(3)}, x_{2P}^{(3)} < v_2 < x_{3PP}^{(3)}]$. Then, substituting all these terms into the expected payoff yields the indifference condition

$$\begin{aligned} & \frac{F(x_{3PP}^{(3)}) - F(x_1^{(3)})}{1 - F(x_1^{(3)})} \cdot \frac{F(x_{3PP}^{(3)}) - F(x_{2P}^{(3)})}{1 - F(x_{2P}^{(3)})} \left\{ x_{3PP}^{(3)} - \frac{F(x_{2P}^{(3)}) - F(x_1^{(3)})}{F(x_{3PP}^{(3)}) - F(x_1^{(3)})} \int_{x_2P}^{(3)} v \frac{f(v)}{F(x_{3PP}^{(3)}) - F(x_{2P}^{(3)})} dv \right. \\ & \left. - \frac{F(x_{3PP}^{(3)}) - F(x_{2P}^{(3)})}{F(x_{3PP}^{(3)}) - F(x_1^{(3)})} \int_{x_2P}^{(3)} v d \left[\frac{F(v) - F(x_{2P}^{(3)})}{F(x_{3PP}^{(3)}) - F(x_{2P}^{(3)})} \right]^2 \right\} - c = 0, \end{aligned}$$

which is equivalent to equation (7d) after integration by parts and rearranging terms.

We then show part (2.b) and part (2.c) of the proposition, and delay the existence of the solution to the equation system in part (2.a).

The next step is to specify the critical participation cost c at which buyer 3 with signal (P, P) has cutoff point $x_{3PP}^{(3)}(c) = \bar{v}$. Provided $x_{3PP}^{(3)} = \bar{v}$, the equation system (7a)–(7d) reduces to the same form as system (6) together with $x_{3PN}^{(3)} = x_{2P}^{(3)}$, which means this critical cost is c_1 . Note that $\lambda(\cdot)$ represents the expected payoff of buyer 3 with value \bar{v} and signal (P, P) , and $\lambda(\cdot)$ is monotonic with $\lambda(c_1) = 0$ from the proof of Lemma 1, then buyer 3 with signal (P, P) would never participate regardless of her value.

Let $x_{3PP}^{(3)} = K$ and ignore the equation (7d). Then equations (7b) and (7c) imply $x_{2P}^{(3)} = x_{3PN}^{(3)}$ due to $F(x_{3PP}^{(3)}) = 1$. Therefore, the expression (7a) reduces to (8a) and (7b) reduces to (8b). These are the conditions stated in part (2.b).

We then show that the two-equation system of (8a) and (8b) has a unique solution for $c \in (c_1, c_0]$. The system of part (2.b) is very similar to the one in Proposition 1 except for $F(\cdot)$ in the first equation (3a) being replaced by $F^2(\cdot)$. Moreover, the conclusions and the proof are exactly the same in both cases including the definition for the upper bound of the cost c which only depends on the second equation in the system. So this two-equation system in part (2.b) has a unique solution for $c \in (c_1, c_0]$.

Immediately for $c \in (c_0, \Delta v]$, we see that there is at most one buyer—buyer 1 who participates in the auction, since buyer 2 finds her expected profit cannot cover her cost at any valuation level even if buyer 3 does not participate. This is because the equations (14a) and (14b) do not have a solution with critical values belonging to $[\underline{v}, \bar{v}]$ for $c \in (c_0, \Delta v]$, which yields the result in part (2.c).

As for the existence of solution in part (2.a), it is now self-evident. For $c \in (0, c_1)$, buyer 3 with signal (P, P) must have a cutoff point less than \bar{v} by the monotonicity $\lambda(\cdot)$. Since all other types of buyers, i.e. buyer 3 with signal (P, N) , buyer 2 with signal P and buyer 1 all confront with weaker opponents on average than buyer 3 with signal (P, P) does, it implies that the cutoff points $x_{3PN}^{(3)}$, $x_{2P}^{(3)}$ and $x_1^{(3)}$ exist, and are less than $x_{3PP}^{(3)}$. This completes the proof. \square

PROOF OF PROPOSITION 6: The argument of this proposition follows the same procedure as the proof of Proposition 5 but is easier since we do not need to specify the regions for different types of equilibria. When calculating the expected profit conditional on winning, the mathematical induction can be used to simplify the procedures to avoid too involving details. Since this is a pure mathematical computation, we omit it. \square

References

- [1] Cao, Xiaoyong and Tian, Guoqiang (2008), "Second Price Auctions with Two-Dimensional Private Information on Values and Participation Costs," working paper.
- [2] Cao, Xiaoyong and Tian, Guoqiang (2008a), "First Price Auctions with Participation Costs," Texas A&M University, working paper.
- [3] Cao, Xiaoyong and Tian, Guoqiang (2008b), "Second Price Auctions with Differentiated Participation Costs," Texas A&M University, working paper.
- [4] Campbell, Colin M. (1998), "Coordination Auctions with Entry," *Journal of Economic Theory*, Vol.82, pp.425-450.
- [5] Chakraborty, Indranil and Kosmopoulou, Georgia (2001), "Auctions with endogenous entry," *Economics Letters*, Vol.72, pp.195-200.
- [6] Cho, In-Koo and Kreps, David M. (1987), "Signaling games and stable equilibria," *Quarterly Journal of Economics*, Vol.52, pp.179-221.
- [7] Gal-Or, Esther (1985), "First Mover and Second Mover Advantages," *International Economic Review*, Vol. 26, No.3, pp.649-653.
- [8] Green, Jerry and Laffont, Jean-Jacques (1984), "Participation Constraints in the Vickrey Auction," *Economics Letters*, Vol.16, pp.31-36.
- [9] Harstad, Ronald M., Kagel, John H. and Levin, Dan (1990), "Equilibrium Bid Functions for Auctions with an Uncertain Number of Bidders," *Economics Letters*, Vol. 33, pp.35-40.
- [10] Kaplan, Todd and Sela, Aner (2003), "Auctions with Private Entry Costs," CEPR Discussion Papers 4080.
- [11] Kaplan, Todd R. and Sela, Aner (2006), "Second-Price Auctions with Private Entry Costs." Available at SSRN: <http://ssrn.com/abstract=442521>
- [12] Krishna, V., "Auction Theory," Academic Press, San Diego, California. 2002.
- [13] Levin, D. and Smith, J.L. (1994), "Equilibrium in Auctions with Entry," *American Economic Review*, Vol.84, pp.585-599.
- [14] Lu, Jingfeng (2006), "Endogenous entry and auctions design with private participation costs," MPRA Paper 934, University Library of Munich, Germany.

- [15] McAfee, R.P. and McMillan, J. (1987), "Auctions with entry," *Economics Letters* Vol.23, pp.343-347.
- [16] Menezes, F.M. and Monterio, P.K. (2000), "Auctions with Endogeneous Participation," *Review of Economic Design*, Vol.5, pp.71-89.
- [17] Moreno, Diegon and Wooders, John (2006), "Auctions with heterogeneous entry costs," *Economics Working Papers in Universidad Carlos III, Departamento de Economia*.
- [18] Samuelson, William F.(1985), "Competitive bidding with entry costs" *Economics Letters*, Vol.17, No.1-2, pp.53-57.
- [19] Stageman, Mark (1996), "Participation Costs and Efficient Auctions," *Journal of Economic Theory*, Vol.71, pp.228-259.
- [20] Tan, Guofu and Yilankaya, Okan (2006), "Equilibria in Second Price Auctions with Participation Costs," *Journal of Economic Theory*, Vol.130, pp.205-219.
- [21] Vickrey, William (1961), "Counterspeculation, Auctions, and Competitive Sealed-Tenders," *Journal of Finance*, Vol.16, No.1, pp.8-37.